

1	2	3	4
Rev.:	Revision note:	Drawn date:	Checked date:
			Approved date:

Tolerance for pressure vessels according to DIN 28005-1			
Range [mm]	Vessel length [mm]	Distance nozzle to reference line [mm]	Nozzle facing to reference line [mm]
>30 - 120	± 3	± 2	± 3
>120 - 400	± 4	± 2	± 4
>400 - 1000	± 6	± 3	± 6
>1000 - 2000	± 8	± 4	
>2000 - 4000	± 11	± 6	
>4000 - 8000	± 14	± 8	
>8000 - 12000	± 18	± 10	

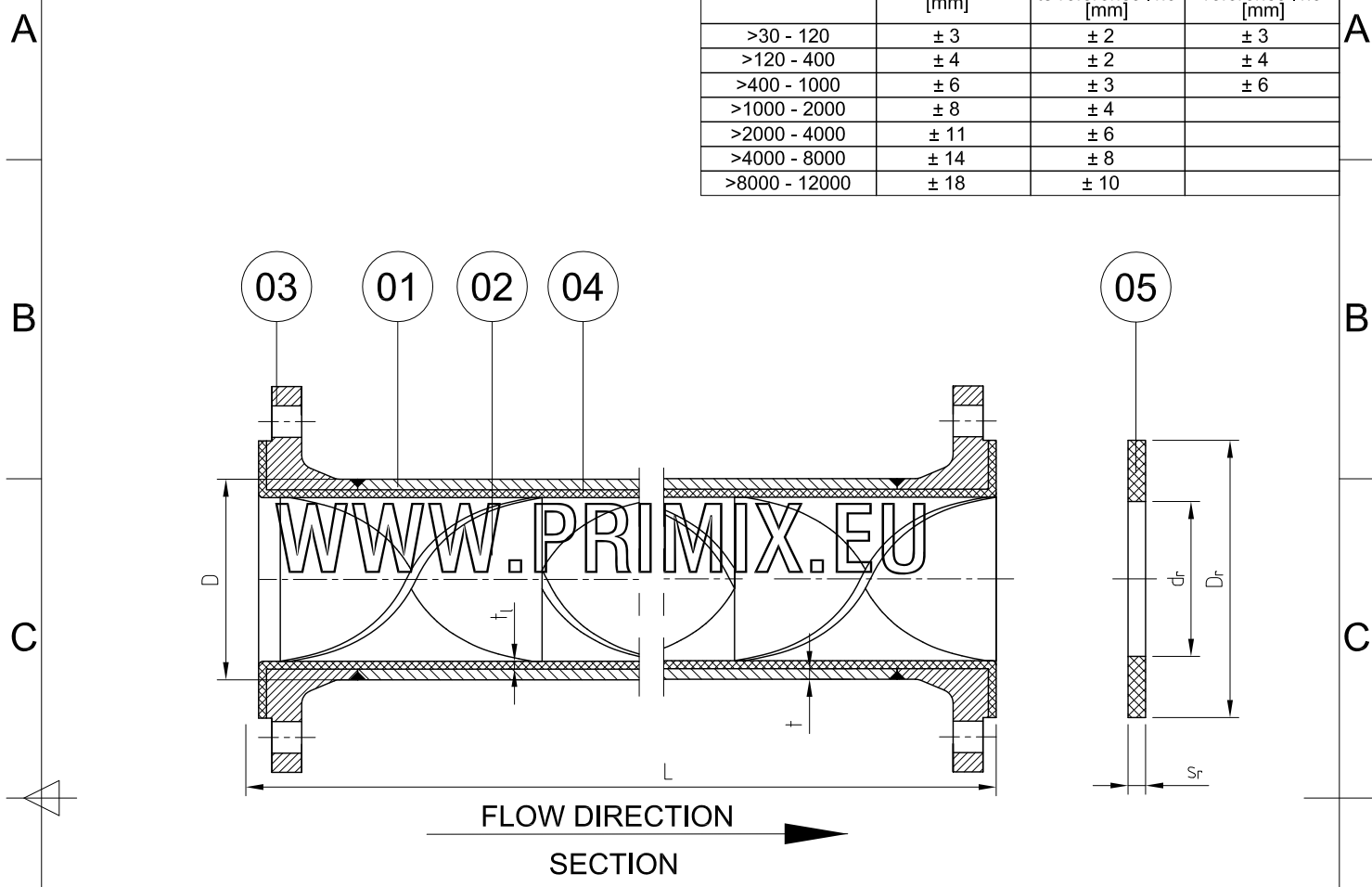

MIXER DIMENSION & WEIGHT (EN1092-1 Type 11 Form B1 flange)																					
Size	Outside diameter D [mm]	Wall thickness t [mm]	Lining thickness t _l [mm]	NUMBER OF ELEMENTS								Outside diameter D _r [mm]	Inside diameter d _r [mm]	Ring thickness s _r [mm]							
				2		3		4		5					6		8				
				L [mm]	W [kg]	L [mm]	W [kg]	L [mm]	W [kg]	L [mm]	W [kg]	L [mm]	W [kg]	L [mm]	W [kg]	L [mm]	W [kg]				
DN15 (PN10/16/40)	21.34	2.0	3	85	1.7	85	1.7	85	1.7	95	1.7	110	1.7	150	1.8	51	11	5			
DN20 (PN10/16/40)	26.67	2.3	3	90	2.4	90	2.4	110	2.4	135	2.5	160	2.6	215	2.7	61	16	5			
DN25 (PN10/16/40)	33.70	2.6	3	90	2.9	120	3.0	155	3.1	190	3.3	230	3.4	300	3.6	71	23	5			
DN32 (PN10/16/40)	42.16	2.6	3	105	4.3	155	4.6	205	4.8	255	5.0	305	5.3	405	5.7	82	31	5			
DN40 (PN10/16/40)	48.26	2.6	3	125	5.0	185	5.3	245	5.7	305	6.0	365	6.3	480	7.0	92	37	8			
DN50 (PN10/16)	60.33	2.9	3	165	6.3	240	6.9	320	7.4	395	8.0	475	8.6	630	9.8	107	49	8			
DN65 (PN10/16)	73.03	2.9	3	205	8.3	300	9.4	400	10.5	495	11.6	595	12.7	790	14.8	127	61	8			
DN80 (PN10/16)	88.90	3.2	3.5	250	11.6	370	13.4	490	15.2	610	17.0	730	18.8	975	22.5	142	76	10			
DN100 (PN10/16)	114.30	3.6	4.5	325	16.4	485	19.9	640	23.3	795	26.8	955	30.3	1270	37.2	162	98	10			
DN125 (PN10/16)	141.30	4.0	5	405	21.0	605	25.1	800	29.1	1000	33.3	1195	37.3	1590	45.5	192	123	15			
DN150 (PN10/16)	168.28	4.5	5	490	27.9	730	34.0	970	40.0	1205	46.0	1445	52.0	1925	64.1	218	149	15			

05	Retaining ring		PTFE		1			
04	Lining		PTFE		1			
03	Welding neck flange	EN1092-1 Type 11 Form B1	316L / 1.4404	3.1	2			
02	Helical Shaped element		PTFE					
01	Housing		316L / 1.4404	3.1	1			
Item No.:	Description:	Reference standard / drawing:	Material:	Mat. Cert.:	No.-off:	Final dimension	Weight:	Rev.:

Drawn by:	Checked by:	Approved by:	Date:	Client ref.:	Project:	Scale:	Format:
MR	RJW	RJW	04/01/2016			1:~	A4
		Projection:	Title:				
Postbus 220, 3640 AE Mijdrecht Nijverheidsweg 17F Mijdrecht The Netherlands www.primix.eu			316L / PTFE LINED MIXER EN Type 11				
Dwg.no.:				Sheet:		Rev.No.:	
PMS - -316L / PTFE-EN(11)				1/1		0	