



# AGITATORS series BLUELINE – SILVERLINE - GOLDENLINE

Composed Series  
“B..” – “S..” – “G..”

## Instructions for installation and use FOR the INSTALLATION, the EXERCISE, the MAINTENANCE

This handbook is destined to the responsible staff of the installation,  
the exercise and the maintenance of this material.

Costruttore:  
PRO-DO-MIX srl  
Via dell'artigianato, 23 - 35026 Conselve (PD)  
Tel 0039 049 9501368 - Fax 0039 049 9501638



### ENCLOSURE LIST

- A) Electric motor instructions manual
- B) Reducer instructions manual
- C) CE Certificate. ....
- D) .....





## INDEX

<b>Safety precautions</b> .....	page 3
1 General .....	4
2 Preliminary inspection .....	4
3 Designation of mixer .....	5
4 Legend of mixers .....	6
5 Legend Options .....	7
6 Applications .....	8
7 Installation .....	8
8 Working Limits. ....	8
9 Start up .....	12
10 Accidents prevention measures .....	13
11 Maintenance .....	14
12 Fault finding chart .....	15
13. Routine maintenance .....	18
<b>Electric motor and reducer instructions manual</b> .....	after page 18



## SAFETY PRECAUTIONS

This symbols    indicate the risk level deriving from failure in observing the prescribed safety precautions:



**DANGER**  
RISK OF  
ELECTRIC SHOCK

Warns that failure to observe the precautions may cause electric shock.



**DANGER**  
GENERIC

Warns that failure to observe the precautions may cause personal injury or property damages.



**WARNING**

Warns that failure to observe the precautions may cause damage to the mixer and/or system.

The machine user must comply with the regulations indicated below to achieve the highest possible safety threshold.

Open or removed guards represent very dangerous safety hazards as this can cause injuries and cuts. The same goes for mechanical hand enclosures (robot).

Cover grilles, grid bars or cover grids are usually already fitted fastened at the time of supply. They can only be removed using tools. Machines featuring such devices must only be operated when these are mounted and fixed.

In the case of set-up overhauling, inspection and maintenance operations, power must always be interrupted to the motor by disconnecting of the phase leads (power leads)

If a machine requires other energy sources-pneumatic, hydraulic, steam or hot water- such supplies must also be interrupted or stopped and the pipes inside the machine must be restored to pressure zero.

Heated or cooled machine parts must be treated with special caution due to the risk of burns..

A machine that has been shut down by an emergency button must not be started again as soon as this button has been reset. The machine will only start again when the master switch is operated.

**Important : the emergency motor stop button should be placed close to the machine.**



**THE RUNNING IN CAVITATION, THAT IS WITH LIQUID LEVEL REACHING THE IMPELLER, IS AUTHORIZED FOR VERY SHORT TIME (FEW MINUTES) IN ORDER TO AVOID MECHANICAL DAMAGES AND/OR COLLATERAL DAMAGES, BECAUSE OF THE FATIGUE STRENGTH OF THE AGITATOR. PLEASE CONTACT PRO-DO-MIX FOR REQUIREMENTS OF OPERATION FOR EXTENDED PERIODS WITH LOW LIQUID LEVEL IN THE CONTAINER.**



## 1. GENERAL

The purpose of this manual is to provide the necessary information for installation, use and maintenance of the mixer. The mixer is manufactured for an industrial purpose and it must be installed and operated only by qualified technicians who know applicable directives and accepted codes of good practice.

The user must read this manual and the attachments before using the mixer.

Improper use could damage the mixer and cause the forfeiture of the warranty coverage.



**The mixer is NOT a “ready to use machine”, but is a component part and it is a POTENTIALLY DANGEROUS device because it has rotating parts that could cause serious injury in case of contact with person or objects.**

**All the rotating parts of the mixer must be segregated in a way that makes impossible the contact with persons, animals or objects when the motor is energized.**

**The responsibility for final product safety and compliance with applicable directives rests with the manufacturer or the assembler who incorporate the mixer as component part.**

**It is absolutely forbidden to put in service the agitator before that the machinery in which will come incorporated is declared in compliance with the enforced applicable norms of SAFETY.**

When asking our office for technical information or spare parts, please indicate the model identification and the construction number found on the nameplate.

The following instruction and warnings refer to the standard models with electric motor; for any variations or characteristics of special versions please refer also to the enclosures and to the sales contract.

For any instructions or situations not referred to in this manual or in the sales documentation, please contact our office.

## 2. PRELIMINARY INSPECTION

Upon delivery check the integrity of the packaging.

After unpacking the mixer make sure that no damage has occurred during shipping (check particularly the linearity of the long shaft). Should the mixer be damaged, write a report together with the carrier, or write « materials acceptance with reservation » on the delivery note. Do not install the mixer and advise PRO-DO-MIX within 3 working days.

### UNPACKING AND STORAGE

The package must be carefully examined on receipt, in order to ensure that the contents are not damaged. Examine the contents and check them off against the delivery note.

The equipment is delivered in 2 packages, 1 package for the shaft, 1 package for the propeller and the reducer gear (eventually, equipped with the motor).

### STORAGE PRECAUTIONS

#### Storage for less than six months:

Equipment shall preferably be stored in its original packaging, protected from adverse weather conditions and impacts, and not too near to vibrating devices as the resulting vibrations may cause wear on the bearings and mechanical mating faces.

#### Storage for more than six months :

The gear should be completely filled with oil, the components should be protected from external cold and damp. Follow the instructions for storage for less than six months.

#### Note

- The shaft should be stored horizontally.
- Any prolonged storage before or after use, in particular environmental conditions (humidity, salinity, vibrations or corrosion) shortens the guarantee application.



### 3. DESIGNATION OF MIXERS

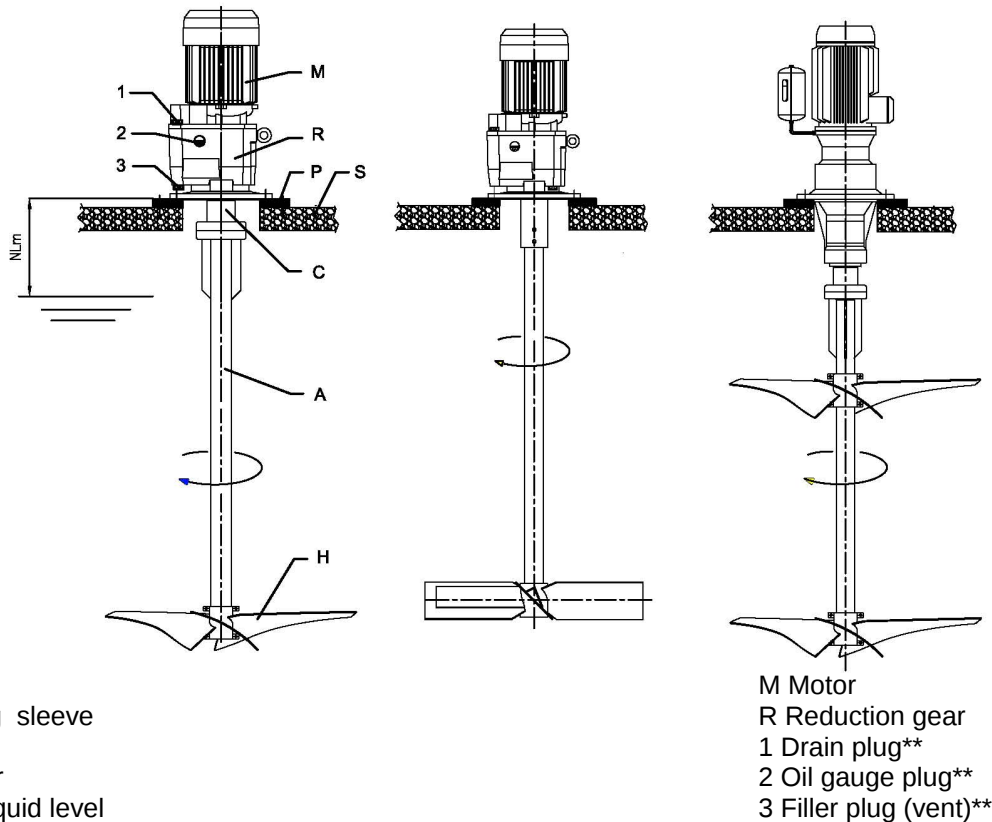

A Shaft  
C Coupling sleeve  
D Support  
H Propeller  
\*L2 High liquid level

M Motor  
R Reduction gear  
1 Drain plug\*\*  
2 Oil gauge plug\*\*  
3 Filler plug (vent)\*\*

\* see technical data sheet

\*\* consults the instruction manual of the gear (it is indicated in the label )

**Fig. 2.1 : Assembly drawing of agitator**

This manual is suitable for the following types of mixers:

- **B..** standard mixers of **BlueLine** series, with electrical motor, gear, with one of our exclusive propeller (4PBT45; 3PM-1084; 3PM-0030; 3PM-0242; 2PM-0650), for atmospheric tanks or vessels, with vertical top mounting, generally used for water treatment applications.  
**BlueLine** series includes 1477 different mixers, fully designed.
- **S..** standard mixers of **SilverLine** series, with electrical motor, gear, with one of our exclusive propeller (4PBT45; 3PM-1084; 3PM-0030; 3PM-0242; 2PM-0650), for atmospheric tanks or vessels, with vertical top mounting, for applications with inert sludge of mines, cement slurry, ceramic slips, glazes and ceramic dyes, motion and flow rate, recirculation basins.  
**SilverLine** series includes 105 mixers, fully designed.
- **G..** special mixers of **GoldenLine** series, with electrical motor, gear, with one of our exclusive propeller (4PBT45; 3PM-1084; 3PM-0030; 3PM-0242; 2PM-0650), for atmospheric tanks or vessels, with vertical top mounting, generally used for different applications in which standard agitators of **BlueLine** and **SilverLine** series are suitable if suitably adapted.

Depending from the construction features or installed accessories, the name of the mixer could be completed by one or more letters with the following meanings (pls. Ref. to NOMENCLATURE and OPTIONS):

EXAMPLE: **BEL.75164.S.250/LHB** means a mixer with shaft and propeller in Aisi 316L for atmospheric top mounting tank, driven by reducer + IEC lantern to install the customer's motor, but supplied without motor, with oil and square support as options, provided with profiled propeller 3PM-0030 diam.1600 mm and shaft length 2500 mm.



## 4. NOMENCLATURE OF MIXERS

### NOMENCLATURE AGITATORS

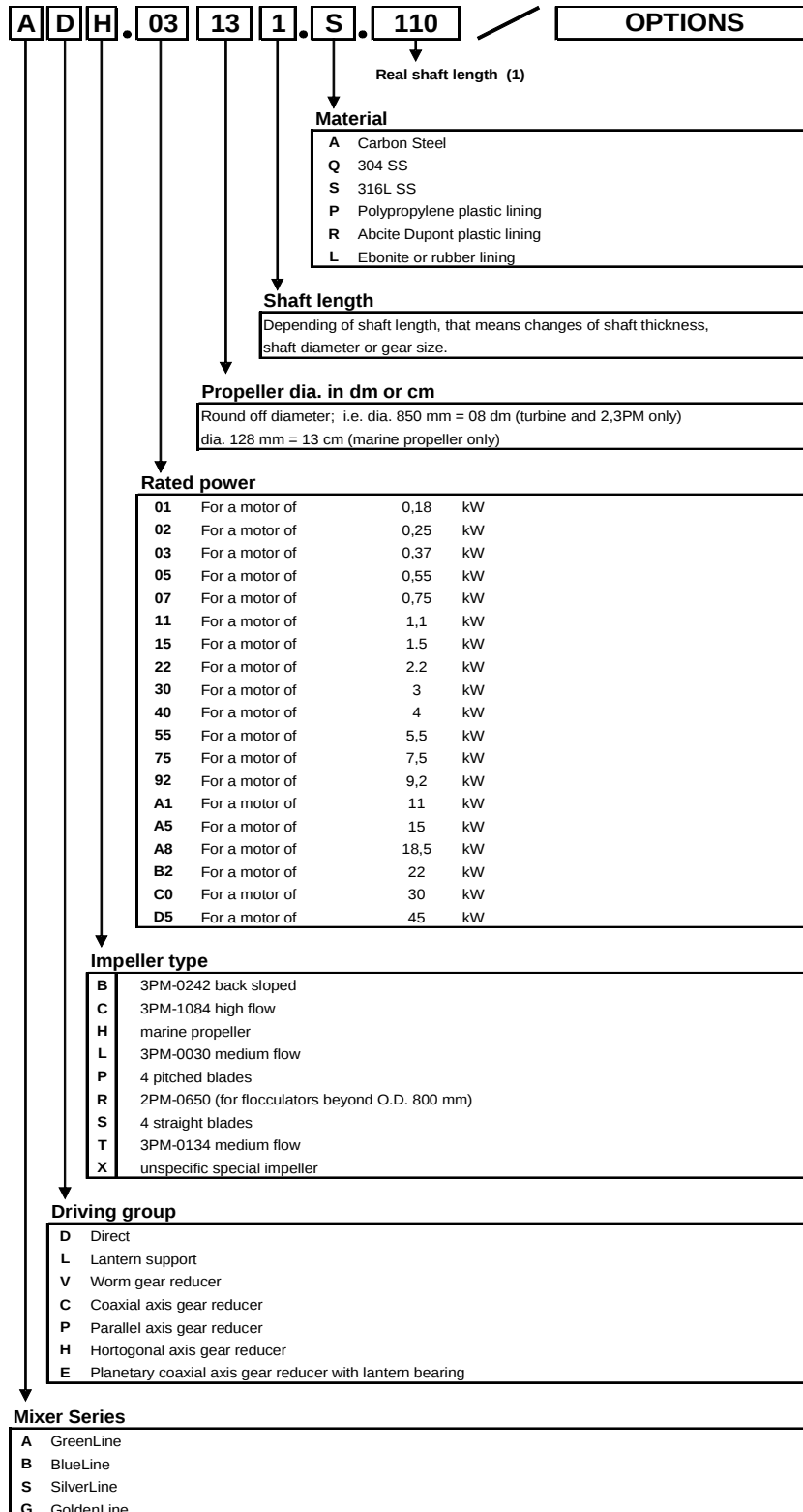

(1) This is the "L" measure stated on the agitator data sheet and not the real shaft length.

I.E.: ADH.03131.S.110 : mixer with direct drive [D], with marine propeller [H], motor power 0,37 kW [03], impeller diameter 128 [13], smaller length of shaft of that range [1], made of s.s. 316 [S] and real shaft length of 110 cm [110].

For a standard model with a modification (or option) not price listed, add Y to the mixer type: AVT.30131.Q.335 / SY (Y= Klicson probes + worm gear)



## 5. NOMENCLATURE OF OPTIONS

### NOMENCLATURE OPTIONS

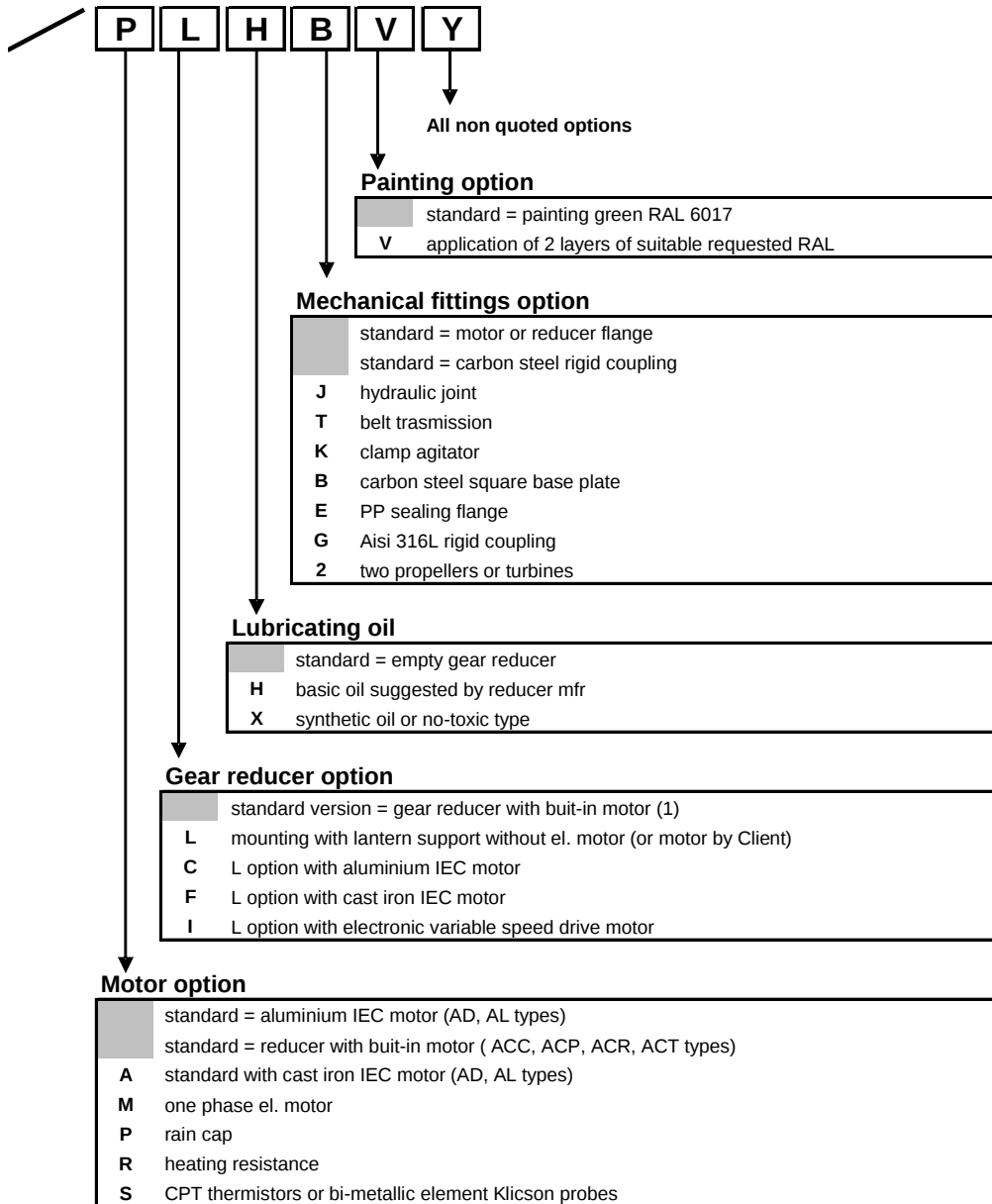

(1) The gear reducer is fitted with a special motor, with a pinion at the shaft end and a special flange.

I.E.: ADH.03131.S.110 / MB : mixer with direct drive [D], with marine propeller [H], motor power 0,37 kW [03], impeller diameter 128 [13], smaller length of shaft of that range [1], made of s.s. 316 [S] and real shaft length of 110 cm [110] with single phase electric motor and a square baseplate.

For a standard model with a modification (or option) not price listed, add Y to the mixer type: AVT.30131.Q.335 / SY (Y= Klicson probes + worm gear)



## 6. APPLICATIONS



The mixer is designed for mixing the fluid with the characteristics (density, viscosity, etc.) specified in the order confirmation or official documentation.

If the above mentioned information are missing, the user will be responsible of checking the mixer and its compatible accessories (ex. Gaskets, materials etc.) with the fluids and the operative conditions it should be applied to.



Working with fluids that are different from the one specified in the contract documents or in the different operative conditions, could damage the mixer and /or the users and / or the boundary things.

## 7. OPERATIVE LIMITS

If not differently specified in the sales documents and certificates: the following data and limits will be respected:



- The mixer is not suitable for dangerous or flammable fluids and it is not intended for use in potentially explosive atmospheres.
- Minimum and maximum working pressure: ATMOSPHERIC
- Fluid to be mixed: ref. to what indicated in the P.O., max density 1,1 kg/dm<sup>3</sup>, viscosity max.100 cP (if not differently indicated)
- Temperature 0 ÷ 80°C (max 45°C with Abcrite lining; max 60°C with rubber lining; max 70°C with Ebonite lining)
- Room Temperature: 0 ÷ 40 °C
- Installation altitude: < 1.000 m above sea level
- Max start up per hour for electrical motors :



Power up to a 5,5 kW	Power up to a 15 kW	Power above 15 kW
20	15	12

## 8. INSTALLATION



### 8.1 Handling

The mixer must be handled with care using suitable hoisting equipment.

For lifting the mixer do not use fragile parts (motor terminal box, hand-wheel of eventual speed variator, etc.) **and also do not use lifting lugs eventually installed on motor, reducer, variator** because the scope of such lifting lugs, if present, is to lift the single component and not the mixer.

Do not use the mixer shaft, if the shaft is bended it can cause vibrations and malfunction.

The best way for lifting the mixer is to wrap up appropriately the motor, the reducer or the lantern if present, avoiding to bend the shaft.

If the shaft and other parts are lined with rubber, ebonite, plastic lining Abcrite or other special paints, these protections are very delicate and can be damaged very easily, for this reason remove the protective devices only when the mixer is placed on site.

### 8.2 Operatin Position

Mixer types B., S., G.. should be installed in vertical position, with the motor upward.





When the tank has a cylindrical section, the baffles are absolutely necessary.

**They can be three or four following the design of the agitator impeller. Three baffles at 120° if the impeller has 3 blades, four baffles at 90° if the impeller has 4 or 2 blades.**

The suggested characteristics are :

**Width** :  $T/10$ , where T is the vessel diameter.

In the case the baffles are distant from the wall, provide a clearance of 2% referring the vessel and a width of baffles of 8%.

With solid suspension or solid dissolution as mixing purpose, the baffles off the wall are preferred..

**Height** : the same of the maximum liquid level, usually until the vessel bottom except in the case of presence of solids in suspension (100 mm about off the bottom).

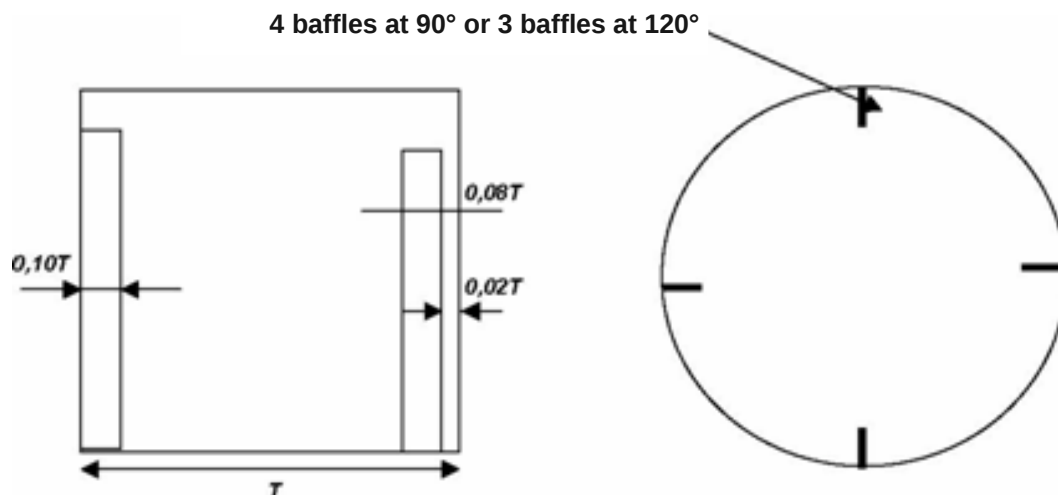

Example : for a tank of 3 m in diameter, the baffles will have the width of 0,30 m or 0,24 m and will have a distance from the tank's wall of 0,06 m.

### o 8.3 Positioning

Before installing the mixer it is necessary to verify the following points:

- The space available around and on the top of the tank / vessel, taking into consideration the shaft length and the space required for the motor cooling.
- The stiffness and the dimensioning of the support structure, considering the static and dynamic loads. The mixer must not be subject to oscillations or vibrations in operation.
- For outdoor installations it is recommended the use of the rain canopy over the motor.
- The dimension of the tank openings for the introduction of the impellers, guide bearings, etc.

### o 8.4 Fixing

Enter the mixer into its seat, paying attention of not to bump the tank.

The mixer must be securely fixed to the relative support by bolts. The bolts must be always the maximum size permitted by the hole of the connection device.

It is necessary to check that the shaft is perfectly vertical and that it does not friction with fixed parts if manually turned.

**Solid shaft** : check rigid coupling and impeller side, in order that screws match the circular caves on the shafts. Pls put only ISO 4028 screws with cylindrical head, while in the other threaded holes, pls put flat head screws ISO 4026.

The screws are supplied with the mixer and they are positioned in the impeller hub and in the rigid coupling.

**We strongly suggest to block all screwing devices with a no-permanent locking like LOCTITE 242® Threadlocker or similar, buyable near all the blacksmith shops, against the unlocking of the**



## **screw during the exercise, also in presence of vibrations, without any problem during the disassembling phase of the maintenance**

The suggested torque wrenchs for T.E. screws and nuts are:

### **TORQUE WRENCH**

Dimensions	Torque wrench
M6	7 m.N
M8	17 m.N
M10	35 m.N
M12	60 m.N
M14	96 m.N
M16	146 m.N
M18	200 m.N
M20	290 m.N

Note : this table is valid for fixing systems class 6.8 (ex. Screws and inox granes)

Dimensions	Torque wrench
M6	10 m.N
M8	23 m.N
M10	47 m.N
M12	81 m.N
M14	130 m.N
M16	195 m.N
M18	265 m.N
M20	380 m.N

Note : this table is valid for fixing systems class 8.8 (ex. Screws and carbon steel granes)

## **Some important notes on bolt tightening**

### **0 How to tighten a screw**



These brief notes refer to tightening screws and are required to develop a pre-established tension. It is well known this result can be achieved using many and various tools made for controlled tightening. Less well known are the implications resulting from the use of these tools and the condition of the screws used. Experience teaches how screws tightening is not always done accurately even using suitable tools designed specifically for that purpose. Often a number of simple operations, necessary for correct tightening, are ignored. To ensure these receive peculiar attention, we shall start from the point that is at the very bottom of the problem – tightening tension.

### **0 Tightening tension**

The life of screw connections is mainly determined by who does the tightening and also by the designer or manufacturer. Of course, the safety of a connection increases if the design is good and the screw is of good quality. There are also cases in which insufficient tightening or over-tightening mainly determine the quality of a connection, according to how strict the use conditions are. To ensure that a connection lasts as long as possible, the screws must be correctly preloaded to reduce up to the minimum the difference between maximum and minimum operating stresses. The diagram below shows “deformation forces” produced on a screw connection and relevant effects: the application of a preload causes the screw to lengthen and, at the same time, the coupled parts to shorten. The work load is partially distributed on the screw and partially absorbed by relaxing of the parts themselves.

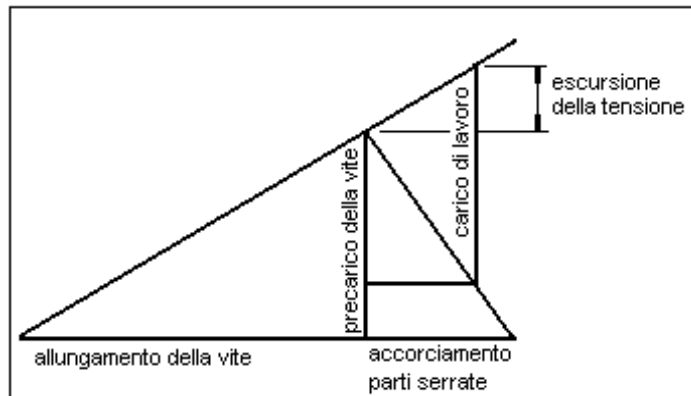

From the test data shown here, performed on big-end connecting screws, the importance of correct tightening becomes evident.

Preload on screws, kg	Workload, kg	tension range kg	No. of supported cycles
650	from 0 to 4200	3.550	5.950
2.700	from 0 to 4200	1.500	35.900
3.300	from 0 to 4200	900	214.500
3.800	from 0 to 4200	400	to 20,000,000 test interrupted

## 0 Controlled tightening operations

There are various systems tightening at pre-established values. The most simple and effective one is the use of spanners or torque meter screwdrivers, with the aid of torque amplifiers in case that higher values are required than the strength of the operator permits. The tension conveyed to the screw during controlled tightening is nevertheless conditioned by the "friction force" produced both between the threads of the screw and nut (or threaded hole) and between the screw head (degree of finish, surface treatment) and the tightening speed.

## 0 Friction forces

Special studies made it possible to assure that, in extreme cases, only 10% of the torque produced by the operator is conveyed to the screw, while the remaining 90% is absorbed by friction. In the case of screw with a thin lubrication covering, as supplied by most manufactures, the friction coefficient is 0,14. This drops to 0,10 for cadmium plated screws and rises to over 0,2 for non-lubricated screws. The torque wrench settings for the different classes of nuts and bolts shown on the following pages have been calculated taking into account 0.10 and 0.14 friction coefficients. No relation can be provided here, not even approximate, between these torques and others resulting from different friction coefficients because very complicated calculations are required to determine them.

## 0 Tightening speed

We have already spoken about the effect of tightening speed on the friction coefficient value. Slow tightening increases this while fast tightening reduces it. Test carried out on M10 screws class 10.9 slightly lubricated, have shown for example:

RPM	Friction Coefficient
0,2	0,186
3,3	0,145
36,0	0,125

In the first case, an 8% reduced tension is produced, while in the third case, this is 4% above the optimum value obtained by applying a speed of 3.3 rpm, considered in the intermediate case, that in fact corresponds to a 90° angle in 4-5 second. It is therefore absolutely vital that the operator adapt to this speed with a constant and continuous action and that on reaching 75% of the necessary value the action be slowed down at the limit of 2 angle degrees per second, as provided by ISO 7355 standards relating to the use of dynamometric wrenches. All the conditions will thus be complied with considered in calculating the torque wrench setting and consequently the tightening tension, a vital characteristic of the connection. This will be





equivalent to or in any case very close to that of the project.

## O Angular tightening

Correct tightening can also be achieved by measuring the screw rotation angle after pre-tightening at low values with a dynamometric wrench. This method provides a precision higher than the one previously explained because it is not affected by general friction forces, screw condition and tightening speed. However, it has its limits such as the angular values that must in all cases of use be predetermined by the designer of the connection as they depend from the elastic features of the connected elements, their size and the quality of the screw. Their use is prevalent in the automotive industry. Angular tightening is done using a goniometric instrument. In the specific case of tightening agitator shaft coupling screws or blade hubs, tightening with a dynamometric wrench is more than enough, after making sure there are no undesired solid particles on the surface to be joined together, checking the screw material and that the threads are adequately lubricated.

## 9. START-UP

### o 9.1 Electrical Connections



**Before start working on the mixer, make sure that the electrical supply has been switched off and that it cannot be accidentally switched on.  
Ground the mixer before making any other connection.**



**We recommend that a high sensitivity differential switch (30 mA) be installed as extra protection against lethal electric shocks in the event of faulty grounding.  
Make sure that the rated voltage corresponds to the supply voltage**

Connect the mixer to the mains using a multiple-pole switch or other device ensuring multiple-pole disconnection (interruption of all the supply wires) from the mains, with a contact separation of at least 3 mm. Remove the terminal board cover by first removing the screws. Carry out the connections as indicated on the back of the terminal board cover and as shown in the specific figure of the motor manual. The electric motor supply must be equipped by the user with a magneto-thermal switch or magnetic starter with overload and under voltage protection, a thermal relay and fuses installed upstream. The overload relay must be set to the rated motor current value .  
**WARNING** : don't forget to branch the ground terminal of the motor (PE) (fig. 9.1) to the grounding line.



**Fig. 9.1 : Motor Clamp-house**

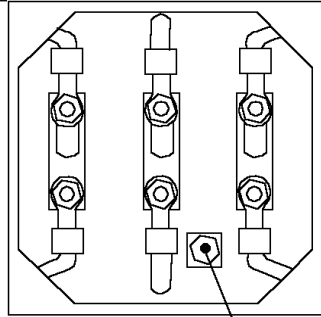

PE

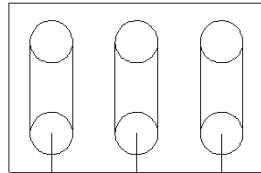

A B C

**fig. 9.1a :**  
**230 V Triphase connection**

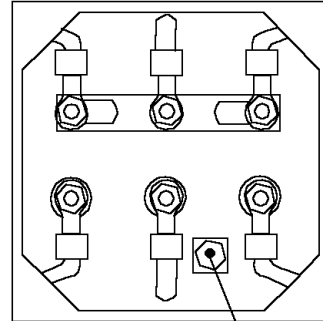

PE

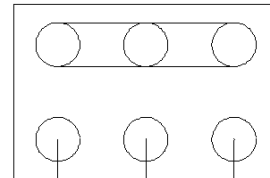

A B C

**fig. 9.1b :**  
**400 V Triphase connection**



## o 9.2 Checking the direction of rotation

The direction of rotation may be checked before the tank / vessel is filled with the fluid to be mixed , provided it is run for very short starts only.



The mixer must not be run until the tank / vessel is filled with liquid.

Continuous dry running (if not stated in the sales documents) can damage the mechanical seal or bend the shaft.

The mixer must not be started (if not stated in the sales documents) if the impeller is immersed in sediments.

Usually the direction of rotation is clockwise when facing the mixer from the motor side, however the correct direction of rotation is shown by an arrow on the mixer.

If necessary reverse the direction of rotation by interchanging one of the two incoming supply wires. (only for three-phase electric motor. For other motors read the relevant manual)

## o 9.3 Controls

Before starting up the mixer it is necessary to check also the following points:



o Check that all the screws and bolts are tightened.

o Check that all the rotating parts are not accessible and all the relevant protections are properly installed.

o For mixers with mechanical speed variator or mechanical speed reducer: check the oil level with the relative indicator, if present, and read the manual. **Never turn the speed control knob when the motor-variator is stopped.**



Imme

o For mixers with double mechanical seal: check the connection of tubes and accessories. Start and check, if required, the correct flow of the flushing or quenching system (read the relevant manual). Immediately after the mixer is started up for the first time verify the following points:

o Check that the mixer do not produce “strange” noise. Otherwise stop it immediately.

o Check that the mixer do not produce evident vibration or oscillation. Otherwise stop it immediately.

o Check that there is not any leakage of oil, grease, water, or other fluids.



o For mixers with mechanical variator or inverter : reach slowly the maximum speed.

o Measure the voltage at the motor terminals and compare it with the rated value on the motor name-plate.

o Measure the absorbed current of the motor for each phase and compare it with the rated value on the motor name-plate. **The motor must never be overloaded.**

## 10. ACCIDENTS PREVENTION MEASURES

### o 10.1 Important



o Press the button “**EMERGENCY STOP**” every time you find in a dangerous situation (this button cannot be provided on the agitator by the manufacturer, so it must be installed close to the machine by the installer or the End User itself).

o Before executing every type of operation in the dangerous areas :

- turn the main switch in position “0” and block it

- put on control panel the warning notice “**OFF FOR MAINTENANCE**”

o In any case avoid every maintenance operation when the agitator is working and avoid the tampering of parts of the agitator.

o All the reparations, especially the ones related with the electrical parts, have to be executed only by specialised staff.

o **NEVER** use the safety devices for different reasons than the ones they are made for.





- Make sure periodically that the safety devices are efficient
- Every person who works on the agitator must be learned about the safety devices assembled on it, if any (depending on the size of agitator) and about their correct use
- **NEVER MODIFY OR TAMPER WITH THE SAFETY DEVICES;**
- PRO-DO-MIX company is not responsible for the operations of modification or tampering made by not qualified staff

## ○ 10.2 Checks, verifications and disposition

Check periodically the condition of :

- IMPELLER-SHAFT
- RIGID COUPLING-AGITATOR SHAFT
- HUB-IMPELLER BLADE
- TANK AGITATOR FLANGE

### Verify always the correct grounding of the machine carpentry

-  On every inspection-door of the vessel, on which the agitator is assembled, place a protection net in order to avoid contacts of persons or object with the inner rotating parts.
- **Vessels should be fitted with warning signs calling attention to the presence of moving parts.**
- ATTENTION : during the employ of agitators is absolutely necessary to be very careful not to disperse the fluids in the surrounding environment; some of them could be toxic or at least dangerous.
- Consult the technical staff of the PRO-DO-MIX in order to choose the correct installation of your agitator and whatever could be necessary for a long life of the machine and to obtain the maximum safety in the use of it.
- **Pay attention to the tightening of the bolts, nut and screws of the agitator. Check them well at the starting and then periodically, because if the impellers or the coupling work loose, it may be generated serious mechanical damages as a consequence.**
-  **Tight the nuts with a dynamometric key, set to the appropriate torque depending on the nuts supplied with the agitator with self locked ones. Reduce the friction coefficient between nut and bolt. We suggest to fix the nut or bolt by means of chemical pastes to increase the locking trend between screwing parts, if the paste is compatible with the process fluid, obviously.**

PRO-DO-MIX technicians are available for providing general advice on installation problems or on choosing materials to be used in contact with the fluids, depending on the fluid's properties and working conditions (e.g. temperature, pressure, tendency to explode etc.) and on any other issue affecting mixer durability and plant safety. PRO-DO-MIX, however, shall not be considered responsible for any suggestions it should be asked to provide because said suggestions derive from previous positive experiences in situations similar to the ones at hand of which PRO-DO-MIX ignores actual plant specifications and process parameters, which remain under the competence of the third parties.

## ○ 10.3 Contraindications

**On the machine there are different parts to which you should pay attention, because they could cause injury to the operator**

- Rotating parts: crushing danger
- Moving parts : break danger
- Sharp parts : amputation danger
- Rotating sharp parts : amputation danger
- Under tension parts : struck by lighting danger





 **Attention : some of the above mentioned parts are dangerous also when the agitator is not working. Always remember to work carefully and maintain always the safety distance also when executing the maintenance operations.**

**Verify in any case that the safety devices are on.**

- ⇒ Never use the machine without protections devices and never modify these devices.
- ⇒ In case of breaking of a protection, repair it immediately or substitute it with another one of the same model.
- ⇒ DO NOT MODIFY OR TAMPER THE SAFETY DEVICES, every operation of tempering or modification made by not qualified staff, cannot be a PRO-DO-MIX company responsibility

## 11. MAINTENANCE



Before start working on the mixer, make sure that:

- The electricity supply has been switched off and that it cannot be accidentally switched on.**
- The tank where the mixer is installed is not in pressure or vacuum.**
- The surface of the mixer and/or the tank is not hot or icy.**
- The eventual steams or smells that can escape out from the tank are not dangerous for people or environment.**



After approx. 100 working hours from the first start-up, check that all the screws and bolts are tightened  
For mixers operating in standard conditions, e.g. room temperature = 0 ÷ 40 °C – mixed fluid temperature 0 ÷ 80 °C, the ordinary scheduled maintenance is the following:

- Mixer with permanently greased ball or roller bearings  
Change the bearings approx. every 15 000 working hours
- Mixer with NON permanently greased ball or roller bearings  
Add a small quantity of clean, specific grease approx. every 5 000 working hours
- Mixer with mechanical speed variator or reducer “life lubricated”.  
No periodic oil changes are required.
- Mixer with mechanical speed variator or reducer NOT “life lubricated”.  
Change the oil after about 300 hours of operation from the first start-up, carefully flushing the gear unit using suitable detergents. Do not mix mineral oils with synthetic oils. Check oil level regularly and change oil approx. every 8 000 working hours. (Read the relevant manual for more specific details)
- See the here attached recommendations of the constructor for the maintenance of the reducer or the chapter **"13. Routine maintenance"**.

For mixers operating out from standard conditions, specific information will be supplied.

Periodically check the regular operation of the mixer and replace the eventual shaft seal, gaskets and elastic elements of the couplings, if any, between motor and reducer and clean, periodically, the motor cooling fan grid and the impeller/s.

For disassembly and assembly procedures read the specific instructions supplied by the mixer Manufacturer.





## 12. FAULT FINDING CHART

<b>Fault</b>	<b>Probable Cause</b>	<b>Possible Remedy</b>
1. The mixer doesn't start	a) No electrical power	Supply electric power
	b) Blown fuses because	Replace fuses with adequate ones
	c) Blown fuses because the	Repair the motor or replace the cable
	d) Overload protection	Reset the protection (if it trips again
2. Overload protection trips	a) Overload setting is incorrect	Check the setting of the motor starter and replace, if necessary
	b) The motor runs on two	Check the electrical connections.
	c) Foreign objects on the	Remove the solids from the shaft and
	d) Density or viscosity of the	Please contact the manufacturer for
	e) Defective bearings	Regrease or change bearings
3. Mixer makes too much noise. Mixer runs unevenly and vibrates	a) Impeller/s draw in air or	Increase the liquid level in the tank
	b) Impeller/s out of balance	Clean and check the impeller/s
	c) The mixer shaft is not	Check the linearity of the mixer shaft
	d) Defective bearings	Regrease or change bearings
	e) Defective motor fan	Replace the fan
	f) the wall are not provided	See point 8.2 for present manual
	g) Defective mechanical	Check oil level or repair the defective



<b>Fault</b>	<b>Probable Cause</b>	<b>Possible Remedy</b>
4. Insufficient or no mixing effect	a) Foreign objects on the	Clean the impeller/s
	b) Impeller/s installed in a	Check that the impeller/s is properly
	c) Wrong direction of rotation	Reverse the direction of rotation
	d) The characteristics of the	Please contact the manufacturer for
5. Too high temperature in the support/lantern, speed variator/reducer or motor	a) The motor is overloaded	See fault 2) and check the motor
	b) Fault in the motor cooling	Check the motor cooling system and
	c) Bearing lubricated with too	Replenish, reduce or replace the
	d) Mechanical speed variator	Replenish, reduce or replace the
	e) The mixed fluid	Check the temperature in the tank. It
	f) The ambient temperature	Check the ambient temperature. It



### 13. ROUTINE MAINTENANCE

#### CHECKING THE LOCKING OF ATTACHING ASSEMBLIES

- 
- Switch off the agitator. Check that the equipment cannot be switched on accidentally.
  - Position a notice at the location of the switch.
  - Check the various attachment fittings on the agitator and check that they are locked.
  - The locking torque is specified in the table of point “8.4 Fixing”.
  - Faulty attaching assemblies are to be replaced with assemblies in the same class.
  - We strongly suggest to block all screwing devices with a no-permanent locking like LOCTITE 242® Threadlocker or similar, buyable near all the blacksmith shops, against the unlocking of the screw during the exercise, also in presence of vibrations, without any problem during the disassembling phase of the maintenance

#### CLEANING THE MOTOR FAN

- 
- This servicing operation ensures good heat dissipation.
  - Switch off the agitator. Check that the equipment cannot be switched on accidentally.
  - Position a notice at the location of the switch.
  - Remove all traces of soiling and dust. Do not use a high-pressure cleaning appliance or pointed tools.

#### CHECKING THE OIL LEVEL IN THE CASING (IN CASE OF DOUBT PLS GIVING PRIORITY TO THE ANNEX MANUFACTURER'S MANUAL OF COMPONENT). Ref. Fig. 2.1

- Wait for the oil to cool before proceeding with this check.
- The oil must be allowed to settle for a certain length of time even after operating for a short period, in order to allow any air bubbles to escape.  
See Figure 2.1
- Switch off the agitator. Check that the equipment cannot be switched on accidentally.
- Position a notice at the location of the switch.
- Unscrew the plug [2] and check that the oil reaches the bore in the plug. Any overflow of oil must immediately be removed, using a degreasing agent suitable for the operating conditions.
- Screw the plug [2] back into place.

#### OIL CHANGE (IN CASE OF DOUBT PLS GIVING PRIORITY TO THE ANNEX MANUFACTURER'S MANUAL OF COMPONENT). Ref. Fig. 2.1

- 
- An oil change must be carried out every 8,000 hours of operation.
  - Switch off the agitator. Check that the equipment cannot be switched on accidentally. Position a notice at the location of the switch.

#### Note

- 
- To avoid any risk of burning by the hot oil, protective gloves should be worn.  
See Figure 2.1
  - Fit a suitable receptacle under the drain plug [3].
  - Unscrew plug [1].
  - Unscrew plug [3] and drain the oil into the receptacle. Protective gloves must be worn
  - to avoid any risk of being burnt by hot oil. The casing must be thoroughly cleaned of any residue of oil or particles.
  - Screw the plug [3] back into place.



- Remove plug [2] (oil level plug). Fill the casing (with a suitable oil for the service conditions) until the oil reaches the level of the bore in the plug [2]. Use a filter (with a mesh size of less than 60 micrometres).
- Screw plugs [2] and [1] back in place.

Remove any overflowed oil immediately, using a suitable degreasing agent for the operating conditions.

Quantity: see the technical characteristics sheet at the end of the manual.

Original oil: mineral oil ISO VG 220 EP

Ambient temperature: - 10°C to + 50°C

Maximum temperature of oil during operation: 90°C

Equivalence table:

ELF REDUCTELF 220

BP ENERGOL GR-XP220

SHELL OMALA 220